

# TUFLOC

## INSTALLATION INSTRUCTIONS

### Dual Vertical Mount Gun Rack (X-Lock)



---

Congratulations and thank you for your recent purchase of the **TUFLOC** gun rack system. Esmet, Inc. has designed and manufactured the highest quality products for over sixty-five years and we are confident that you will be a satisfied Tufloc product owner.

This manual includes simple step-by-step instructions to install, operate and maintain your gun rack. Please contact the factory if you have any installation or operation questions.

## X Dual Vertical Mount

Tufloc Dual Gun Racks are custom designed to secure specific gun models. Dual Gun Racks are shipped with the components already attached. **All Gun Rack components are necessary to properly secure the gun. Do not remove components.** The Dual Gun Rack shown on the front page is for a Remington 870 on the Driver Side and an AR-15 on the Passenger Side. It is for illustration purposes and may not be identical to the gun rack you received.

### Hardware Kit

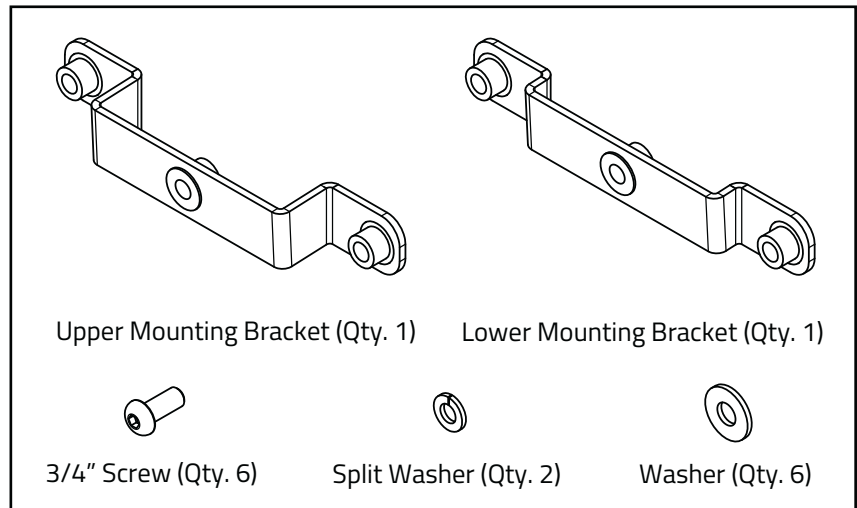

### Ensure a Proper Fit

1. It may be necessary to adjust the components to fit a specific make/model of gun. To make these adjustments, use the key to open the Gun Lock.
2. Without completely removing the 3/4-inch Allen Head Screws, use a 3/16" Allen Wrench to loosen the Screws. This will allow the Gun Lock to slide along the channel.
3. Place the gun in the Dual Gun Rack and slide the Gun Lock along the Back Plate. The proper position of the Gun Lock will keep the gun from being lifted out of the Butt Pocket. **(See Detail A)**
4. The Butt Pocket may also need to be adjusted. For up/down adjustment, loosen the 1/4" Hex. Flanged Nuts on the rear of the Back Plate. For in/out adjustment, remove the Pocket Insert and loosen the 1/4" Flat Socket Cap Screws in the Butt Pocket. **(See Detail B)**
5. Once all adjustments have been made, tighten all the fasteners, ensure that the Pocket Insert has been re-installed into the Butt Pocket and verify that the gun fits securely by locking it in the Dual Gun Rack. Repeat this for the other side.

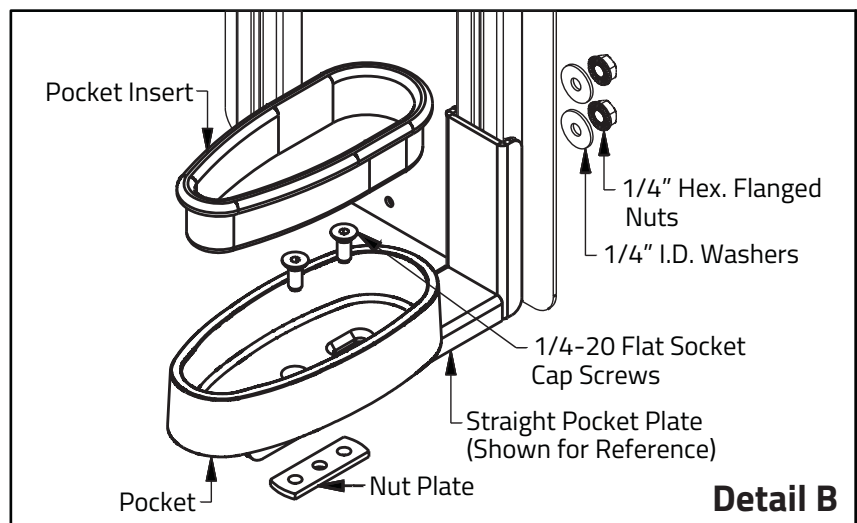
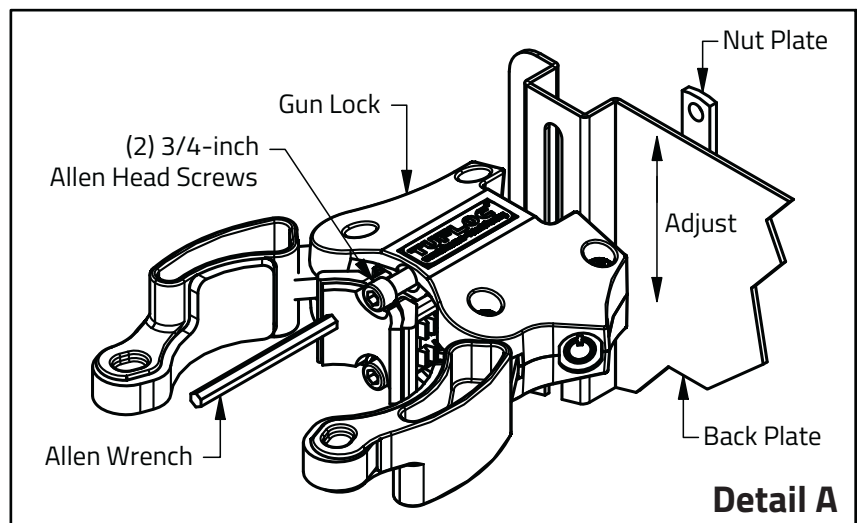

## Mount Brackets to Partition

1. The Upper and Lower Mounting Brackets will be mounted to the Recessed Panel. Make sure the tall bracket is used in the top location. Make sure the longer legs of each bracket are facing upwards.
2. Some partitions have pre-drilled holes and these holes can be used to secure the Mounting Brackets. If the recessed Panel does not have pre-drilled holes, it will be necessary to drill four  $\frac{3}{8}$ " holes into the Recessed Panel. A Mounting Bracket can be used as a template to mark the holes. See Detail A for dimensions.
3. Mount the Brackets to the Recessed Panel making sure the Brackets are in the correct configuration as is explained in Step 1.

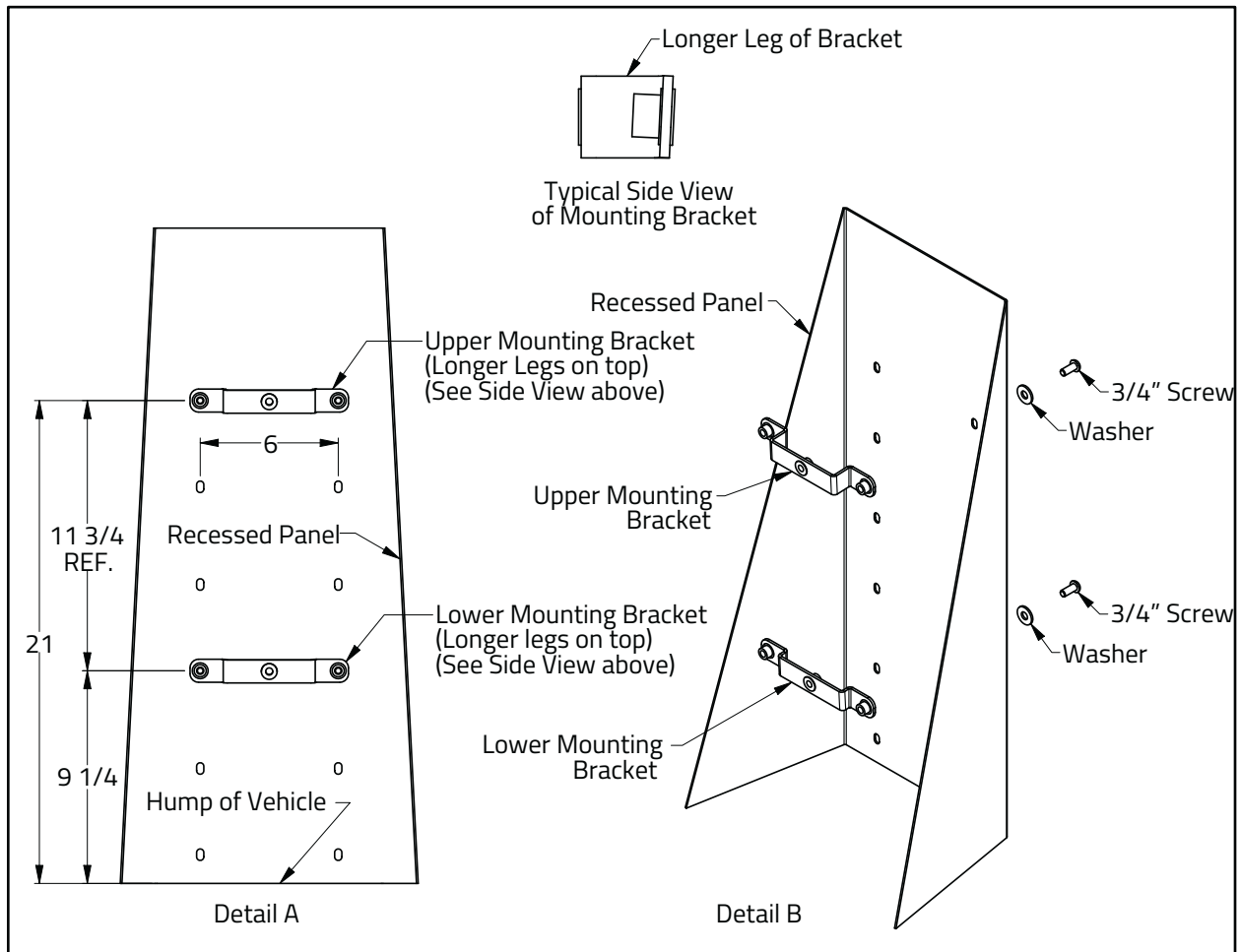

## Mount Gun Rack to Recessed Panel

For clarity, the Gun Rack is shown without the Lock or Butt Pocket

1. Begin preparation for electrical wiring. Attach and insulate the wires following the enclosed wiring diagram. Ensure that the wires are not pinched as they are routed towards the most convenient power and grounding source.
2. With the guns removed, secure the Dual Gun Rack to the center of the Mounting Brackets with the (2) 3/4" screws, Split Washers and Washers.
3. Place guns into the Dual Gun Rack to make sure they fit properly, and they cannot be removed when locked in place.
4. Finalize wiring the Gun Locks per the Electrical Instructions.

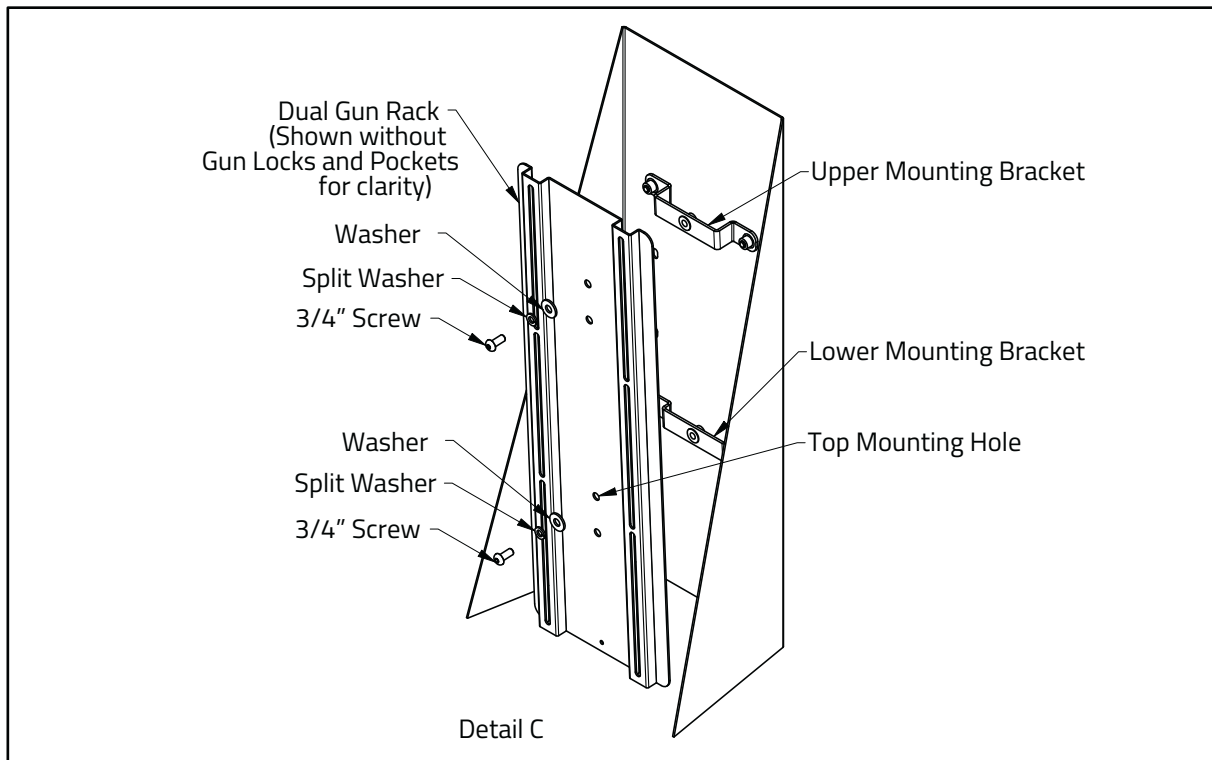

## Important Safety Information

Place the Accidental Discharge and the Lock Operation stickers that are included in the Wiring Kit in a visible spot on the Gun Rack.